

F. Brandon,
Turning Ovals.

N^o 38,461.

Patented May 12, 1863.

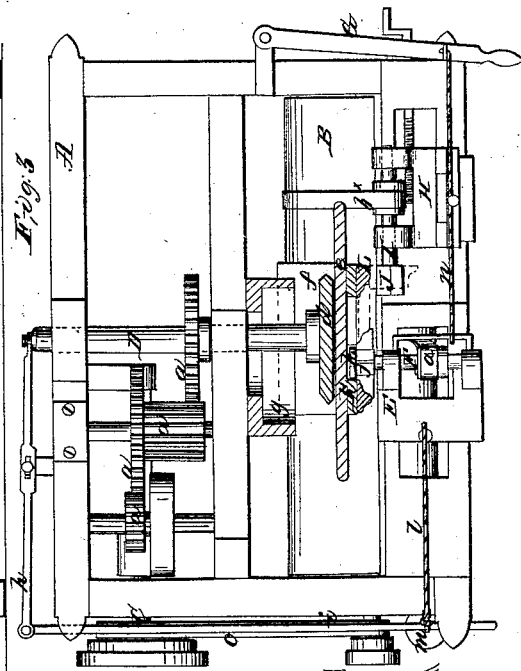
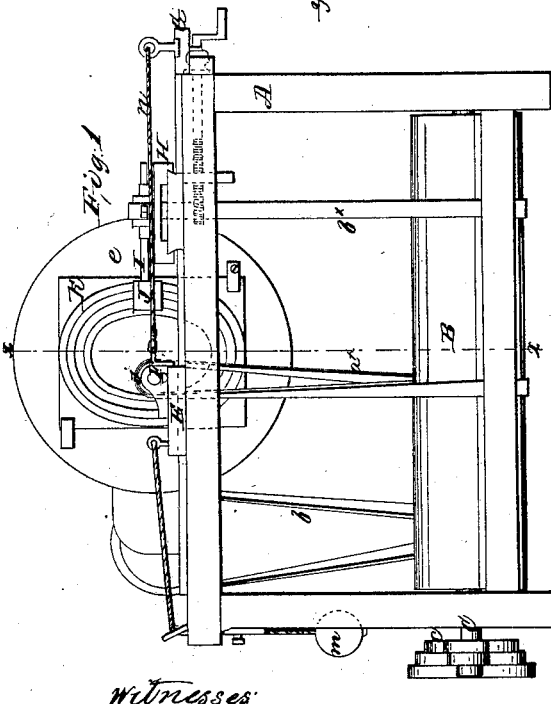
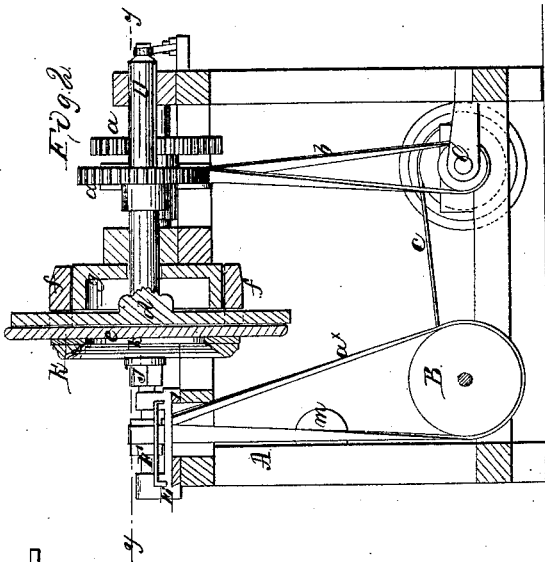

Witnesses:
J. S. Shuman
R. S. Shuman

Inventor:
Francis Brandon
per Wm. H. C. Adams

UNITED STATES PATENT OFFICE.

FRANCIS BRANDON, OF ALBANY, NEW YORK.

IMPROVED MACHINE FOR PLANING OVAL MOLDINGS.

Specification forming part of Letters Patent No. **38,461**, dated May 12, 1863; antedated November 2, 1861.

To all whom it may concern:

Be it known that I, FRANCIS BRANDON, of Albany, in the county of Albany and State of New York, have invented a new and Improved Machine for Cutting or Turning Oval Frames; and I do hereby declare that the following is a full, clear, and exact description of the same, reference being had to the annexed drawings, making a part of this specification, in which—

Figure 1 is a front view of my invention. Fig. 2 a vertical section of the same, taken in the line *x x*, Fig. 1; Fig. 3, a plan sectional view of the same, taken in the line *y y*, Fig. 2.

Similar letters of reference indicate corresponding parts in the several figures.

The object of this invention is to obtain a machine by which beads and concaves or hollows may be turned or cut on the face of oval frames at one operation, the work being done expeditiously and in a perfect manner, the invention also admitting of different-sized ovals being turned or cut with one and the same pattern.

The invention consists in using, in connection with an oval chuck or lathe, a stationary and a sliding cutter, the cutting-planes of which are at right angles to each other, and all the parts arranged, substantially as hereinafter described, to effect the desired end.

To enable those skilled in the art to fully understand and construct my invention, I will proceed to describe it.

A represents a rectangular frame, which may be constructed in any proper way to support the working parts of the machine. In the lower part of the frame A there is placed longitudinally a drum, B, and a shaft, C, the shaft and drum being parallel with each other. On the upper part of the frame A there is placed a shaft, D, which is rotated from the shaft C, at the lower part of the frame A, through the medium of gearing *a* and a belt, *b*. The shaft C receives its motion from drum B by means of a belt, *c*. To the inner end of the shaft D there is attached a cross-plate, *d*, which serves as a guide or way for a plate, *e*, to the face of which the pattern and work are attached, the cross-plate *d* passing through flanges *ff* at the back of the plate *e*, and said flanges projecting over the sides of a circular head, *g*, which is attached to the frame A ec-

centrically with shaft D, as shown clearly in Fig. 3. The above-named parts constitute what is known as the oval chuck or lathe in general use, and therefore does not require a minute description. The shaft D has a longitudinal sliding movement allowed it, said shaft being adjusted, when necessary, by the lever and rod *h i*, both of which are shown in Fig. 3. On the front part of the frame A there is placed a slide, E, having a cutter-shaft, F, upon it parallel with shaft D. The shaft F has a suitable cutter-head, *j*, on its inner end, and a roller, *k*, is also placed thereon in front of the cutter-head. The slide E has a rope and weight, *l m*, attached, and a lever, G, is connected to said slide by a rope, *n*, the ropes being attached to opposite ends of the slide. On the front part of the frame A there is also placed a slide, H, on which a cutter-shaft, I, is placed, having a position at right angles with the cutter-shaft F of slide E. The shaft I is provided with a suitable cutter-head, J. The slide H is also moved or adjusted in a line at right angles to that of the slide E, but the slide H has not a constant sliding motion. The cutter-shafts F I are rotated from drum B by belts *a x b x*. To the face side of the plate *e* of the chuck or lathe there is secured a pattern, K. This pattern is simply an oval opening or recess cut in a wooden plank or board, the oval recess corresponding in form to the oval to be turned.

The operation is as follows: The stuff L shown in red is got out in proper form and secured to the pattern K, and the drum B is rotated by any convenient power, motion being communicated therefrom to the shaft D and to the cutter-shafts F I. The roller *k* of the cutter-shaft F bears against the side of the oval recess which forms the pattern K, the weight *m* keeping the roller in contact therewith, and the cutter-head *j* cuts the inner part of the stuff L in proper form, the slide E moving on the frame under the rotation of the pattern, so that the cutter-head *j* always keeps in a proper relative position with the work or stuff L. The cutter-head J, however, has no sliding movement. It merely rotates in a stationary position, as it is so adjusted relatively with the work or stuff L that the latter in turning moves in the cutting-path of the head J. The cutter-head J cuts the outer

part of the frame L. The stuff or frame L is adjusted to the cutters by actuating the rod *i*, and when the work is done the shaft D, and consequently the plate *e*, and the work is shoved back from the cutters, so that a finished frame may be readily detached from the pattern K, and stuff for a succeeding frame attached to the pattern. Different-sized frames may be turned or cut by employing different-sized rollers *k*, a frame smaller than the pattern projecting over or beyond the edge of the pattern and requiring a roller, *k*, of larger diameter than a smaller frame. By employing the two cutter-heads, arranged in relation with the work and operating as shown, the work is done in a perfect manner and very expeditiously. A single cutter-head rotating on a shaft parallel with the face of the work and extending its whole width would not operate perfectly on account of the oblique position which the cutter-head has relatively with the work at certain points of its rotation—a result

due to the elliptical form of the work. This varying of the position of the stuff and cutter-head relatively with each other precludes the cutting in a perfect manner of beads and hollows on the work by a single cutter-head. The work may be roughly done, but "finishing" or after-labor would be required to perfect the operation.

Having thus described my invention, what I claim as new, and desire to secure by Letters Patent, is—

The arrangement with each other, and with the pattern K, and eccentrically-rotating face-plate *e*, of the self-adjusting cutter *j* and the adjustable cutter J, the said cutters acting upon the work at right angles to each other, all in the manner and for the purposes herein shown and described.

FRANCIS BRANDON.

Witnesses:

J. J. GALLUP,

TERRENCE SHERIDAN.